

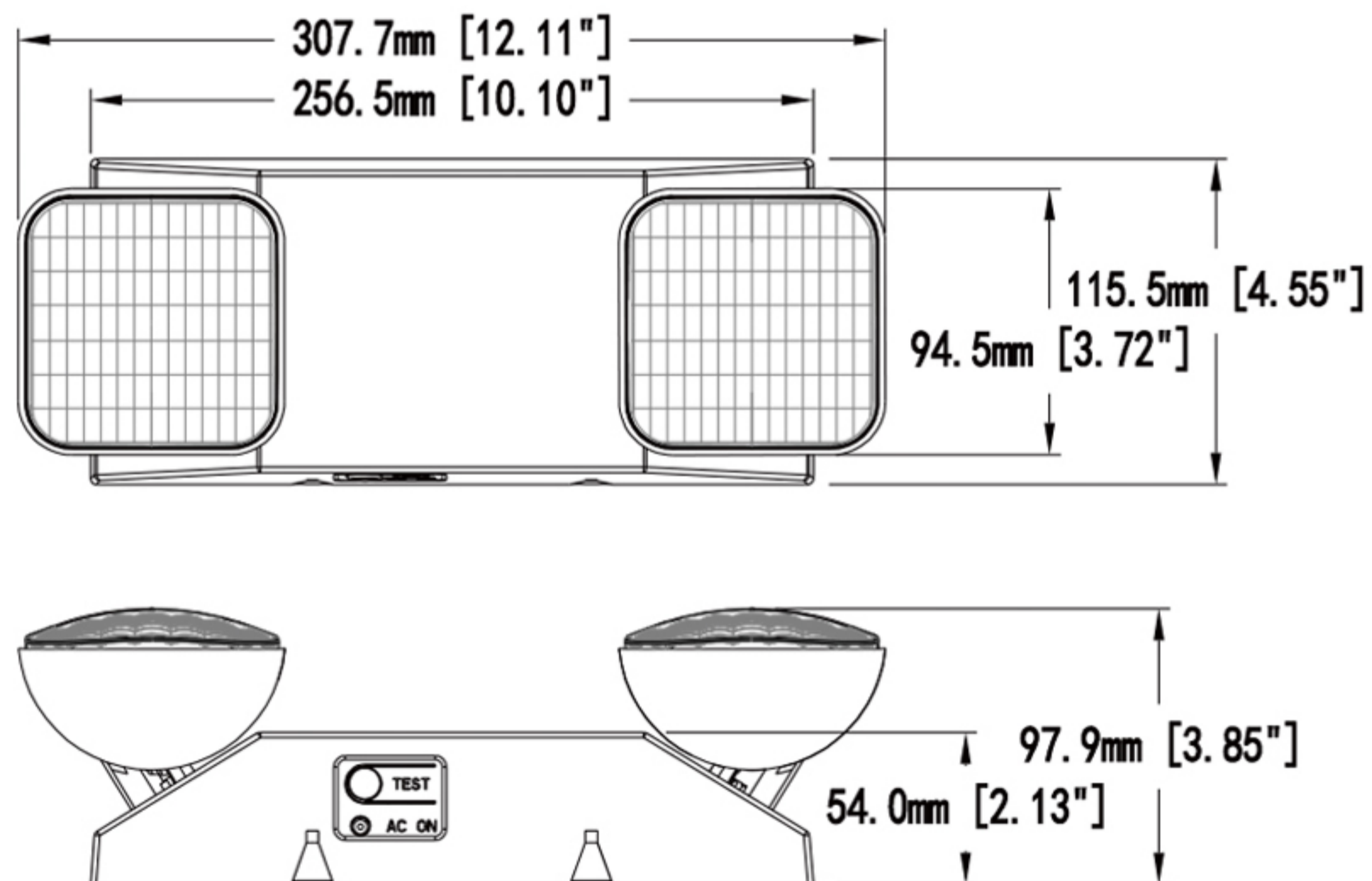

LEDEML LED EMERGENCY UNIT

DIMENSIONS



ILLUMINATION

- Long lasting, efficient ultra-bright white LED lamp heads.
- High-performance chrome-plated metalized reflector and plastic lens for optimal light distribution.
- Adjustable LED lamp heads provide optimal center-to-center spacing.

ELECTRICAL

- 120-347V.
- Charge rate/power "ON" LED indicator light and push to test switch for mandated code compliance testing.
- Long-life, maintenance-free, rechargeable NiCd battery.
- Internal solid-state transfer switch automatically connects the internal battery to LED lamp heads for minimum 90-minute emergency illumination.
- Fully automatic solid-state, two-rate charger initiates battery charging to recharge a discharged battery in 24 hours.

MOUNTING

- Surface mount via quick-connect back plate; fits most standard size junction boxes and snaps into place to make internal electrical connections.
- Conduit mount knockout on top of housing and back plate.
- Suitable for wall or ceiling mount.

HOUSING

- Injection-molded, engineering-grade, 5VA flame retardant, high-impact resistant, thermoplastic in white or black finish.

WARRANTY/LISTING

- Five year warranty on all electronics and housing. Batteries pro-rated for five years.
- UL listed for damp locations.
- Meets UL924, NFPA101 Life Safety Code, NEC, OSHA, Local and State Codes.

ORDERING INFORMATION

Model	Housing
LEDEML01	W White B Black